

L3

L4

# AGILE

Destination Controls &  
Design Center



# AGILE DESTINATION CONTROLS & AGILE DESIGN CENTER

## AGILE: experience the journey

People are what make buildings special. As leaders of urban mobility, we put all our energy into making the journey for people inside buildings not only as efficient as possible, but also as pleasant as possible.



### **AGILE Destination Controls:**

Elevate the efficiency of your current elevator system and move people smarter.



### **AGILE Design Center:**

Customise the graphic interface of your Destination Control terminals for a richer user experience.



# CONTENTS

## 04

### AGILE Destination Controls

- 05 How it works
- 08 Adapt our controls to fit your needs
- 09 Functions

## 12

### AGILE Destination Controls: Terminals

- 12 Get to know our terminals
- 13 Terminal 12"
- 14 Terminal 7"
- 16 Turnstile display
- 18 Modules
- 20 Pedestals
- 22 Wall covers
- 24 Slim wall covers

## 27

### AGILE Design Center

- 28 Display layout style
- 29 Input modes
- 32 Elevator assignment modes
- 33 User interface customisation

# SMOOTH PASSENGER FLOW, HAPPY USERS



# AGILE Destination Controls

Transporting passengers has never been so intuitive and efficient.

AGILE Destination Controls is an advanced dispatching system that directs passengers to the elevator that will get them to their destination in the most efficient way. By grouping people together based on the floor they are traveling to, the number of stops is reduced – thereby improving the efficiency of the building’s elevators.

Add this highly adaptable solution to your new or existing elevator systems and benefit from shorter ride times, fewer stops and less congestion compared to conventional elevators without intelligent dispatching.

On request, a TK Elevator sales representative will analyse your building-specific requirements and provide the ideal solution.

**Increase handling capacity up to**

**30 %**

**reducing travel time by**

**25 %**



- Controls elevators in a coordinated way to use your elevator capacity more efficiently
- Assigns elevators to specific high-traffic areas as user demand changes
- Moves large numbers of people during peak hours
- Building-specific optimised system design
- Customisable features to match the specific needs of your building, e.g. VIP service, support for disabled people or cleaning function
- Choice of terminals and pedestals to complement the building aesthetic
- User-friendly terminal with a variety of options

# INTELLIGENCE GOING UP

- Less congestion in the lobby during high traffic periods leads to smooth and stress-free access to destination
- Improved passenger comfort with less crowded elevators
- Added-value for your building to attract and retain tenants
- Improves building aesthetics
- User-friendly terminal with a variety of options



## Conventional operation

Passengers crowd into lobbies and press elevator push buttons that can only register limited information – basically just single “up or down” requests. The passengers then board the first elevator that answers the call.

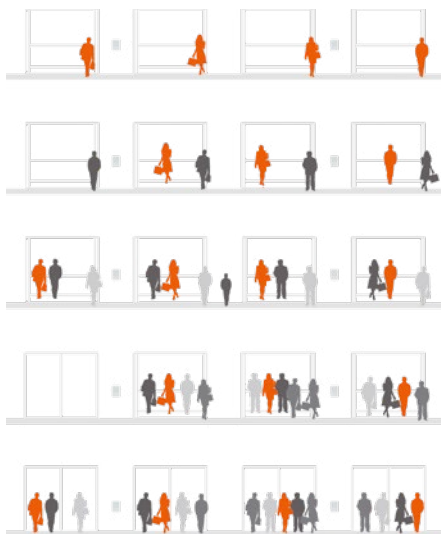

For individual passengers, this means that they have to make a large number of intermediate stops before they reach their desired destination floor.

## AGILE Destination Controls operation

Passengers use a terminal in front of an elevator group to select their floor. The intelligent dispatching software collects this information, analyses the requests, gauges traffic demand and groups them based on similarity of destination.

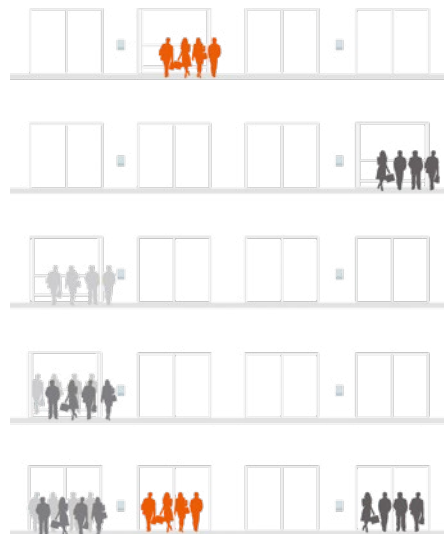
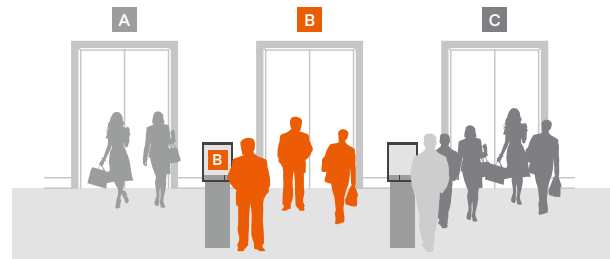

AGILE Destination Controls groups the passengers and guides them directly to the most suitable elevators. This considerably reduces the number of intermediate stops and the time before reaching the desired destination floor.

# How it works

Powered by intelligent controller algorithms, AGILE Destination Controls intelligently groups together passengers who are traveling to similar floor destinations. Unlike conventional operation, a floor is chosen at the AGILE Destination Control Terminals in front of an elevator group and the intelligent dispatching software analyses the request – gauging traffic demand and grouping passengers based on similarity of destination. This leads to less crowding, fewer stops and more efficient use of available elevator capacity.

## Step 01

Passengers use the terminal to select their floor. You can add custom button labels and logos to make the process even easier.

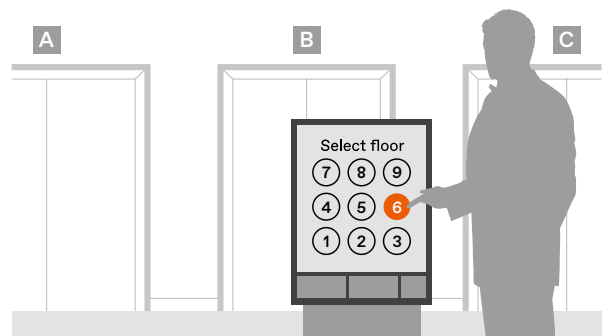

## Step 02

The terminal clearly directs each passenger to an assigned elevator.

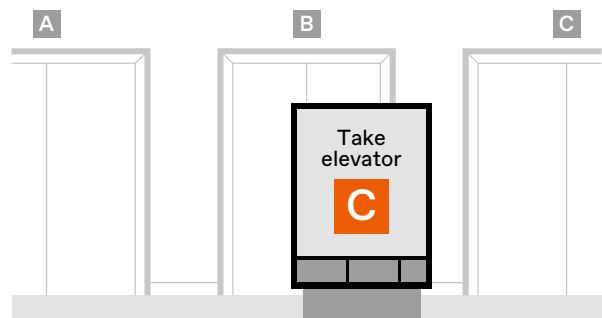

## Step 03

Passengers board the assigned elevator that transports them to their destination.

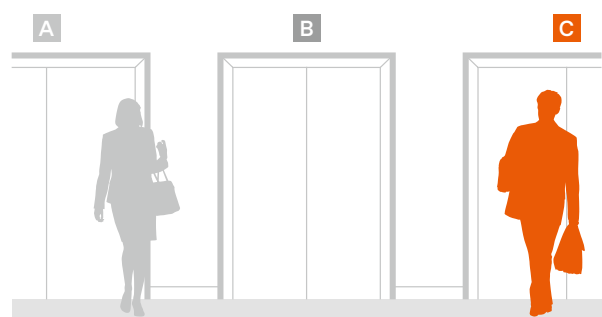

# Adapt our controls to fit your needs

AGILE Destination Controls is flexible enough to seamlessly adapt to new and existing elevators – even during elevator modernisation.

## AGILE Destination Controls

This configuration takes advantage of the full range of AGILE Destination Controls features and can be installed on elevator modernisation projects or new installations.

- One or more terminals on every floor
- No push-buttons inside the car
- Maximum efficiency
- Ideal for complex, high-traffic buildings
- Easily integrates with new or existing security system

## AGILE Destination Controls Booster / Hybrid

If your building has high-traffic conditions on only a few floors, then AGILE Destination Controls is a cost-effective solution for modernisations as well as new installations.

- Terminals on the main floor or selected floors
- Push-buttons inside the car
- Improved efficiency in selected areas\*
- Ideal for buildings with high traffic during peak hours on certain floors
- Easily integrates with new or existing security systems

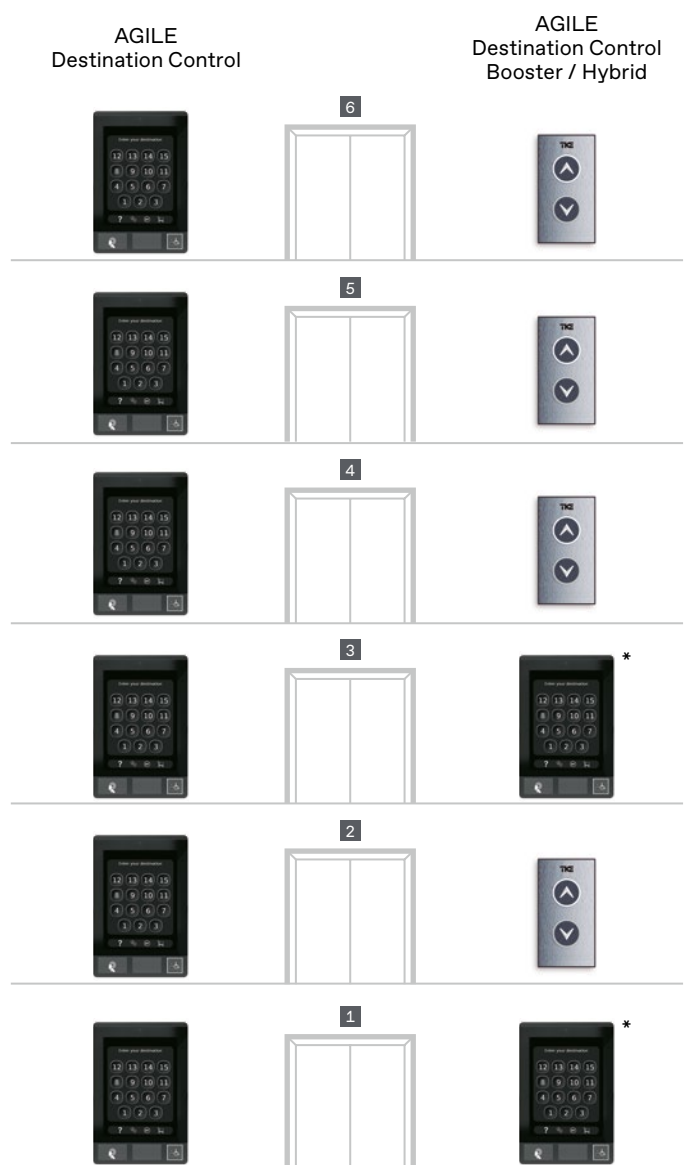

\*In high-traffic areas only, such as a lobby or cafeteria.

# Functions

AGILE Destination Controls offers various functions for specific transportation needs and patterns of use in different buildings. A large variety is already included as a product standard.

## Standard functions

### Normal mode (via terminal)

Operation of the group of elevators by passengers via the terminal to reach a desired floor.



Normal mode for destination floor selection via terminal

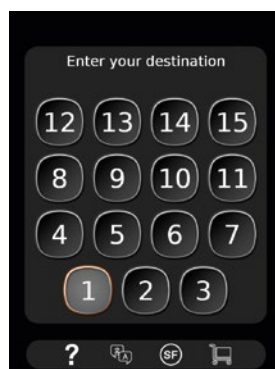

Selection of the destination floor



Elevator assignment

### Handicapped mode

Facilitates the operation of groups of elevators for disabled people, in particular those with impaired sight or mobility, via mobility by acoustic guidance and extending walking and door dwell times.

Complies with EN 81-70.



Activation of handicapped mode by pressing hardware accessibility button



Audible explanation of how to use function and listening in ascending order of the landings for destination floor selection



Elevator assignment and audible announcement regarding assignment and location of the elevator

Non-standard functions and additional functions beyond these shown depend on the project and need to be checked with your TK Elevator sales representative.

# Standard functions

## Cleaning mode

Provision of an elevator car at the requesting floor for cleaning or maintenance purposes. Activation/deactivation by authorised staff.\*



Activation of the special function



Input of the PIN to activate the cleaning mode



Selection of the elevator for cleaning

## Basic transport mode

Enhanced convenience when using the elevator with baggage (e.g. suitcases, small loads) by extending walking and door dwell times. If required, any user can activate the function without special authorisation.



Activation of the basic transport mode

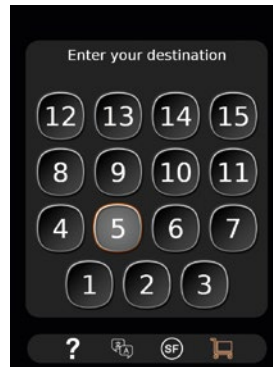

Selection of the destination floor

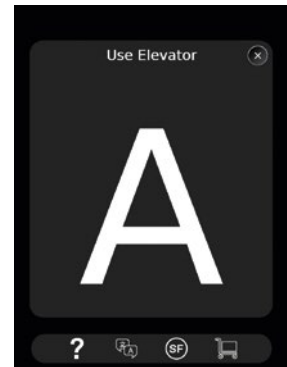

Elevator assignment

## VIP mode

Prioritised use of an elevator car for a VIP, preferably without other passengers and without intermediate stops at other floors. Activation by authorised persons.\*



Activation of the special function

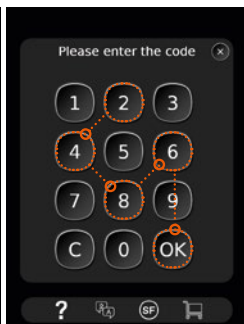

Input of the PIN to activate the VIP mode

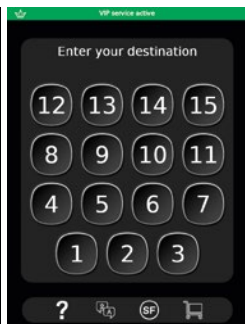

Confirmation that VIP mode is active



Selection of the destination floor



Elevator assignment

\* Possibly with restrictions on elevator use for other passengers.

## Optional functions

### Normal mode (via turnstile)

Operation of the group of elevators by passengers via a turnstile equipped with the terminal and access control system to reach a desired floor.

### Firefighter mode

Immediate request for the fire service elevator in accordance with EN 81-72 as quickly as possible for exclusive use by the fire service via the car operating panel (COP). Activation/deactivation by the fire service using a key-operated switch.\*

### Discreet mode

Exclusive use of an elevator car for discreet passenger transport, for example for medical reasons, hospital bed transport or similar, with extended walking and door dwell times. Activation by authorised staff.\*

### Advanced transport mode

Exclusive use of an elevator car for (large) freight transport with extension of the walking and door dwell times, in particular when loading and unloading. Activation by authorised staff.\*

### Medical emergency mode

Immediate request for an elevator car as quickly as possible for prioritised use as passenger transport in a (medical) emergency or for rescue (e.g., an emergency patient). Activation by authorised staff.\*

### Distribution mode (via COP)

Exclusive use of an elevator car for time-saving distribution of mail/internal mail or for other minor transport tasks on different or all levels in the building. The function is operated using the push buttons for the next floor on the car operating panel (COP). Activation/deactivation by authorised staff.\*

### VIP exclusive mode

Exclusive use of an elevator car for a VIP, without other passengers and without intermediate stops at other floors, possibly with restrictions on elevator use for other passengers. Activation by authorised persons.\*

### Car to car rescue mode

In the unlikely event of an elevator car becoming stuck between floors, passengers can be rescued by crossing to an (operational) elevator traveling in parallel. Activation by authorised staff.\*

## Extended functions

### Shuttle mode

Continuous shuttle operation of an elevator between two selected floors with automatically opening/closing doors, for efficient transport of large passenger volumes. Activation/deactivation by authorised staff.\*

### VIP provisioning mode

Preventive timely provision of an elevator car for later use by a VIP or for other functions. The elevator car travels to the landing from which the function was activated, remains stationary with opened doors, and waits for input of a destination floor. Activation by authorised persons.\*

### Distribution mode (via terminal)

Exclusive use of an elevator car for time-saving distribution of mail/internal mail or for other minor delivery tasks on different or all levels in the building. The function is operated using the touch buttons for the next floor on the terminal. Activation/deactivation by authorised staff.\*

### VIP express mode

Immediate request for an elevator car for exclusive use by a VIP, without other passengers and without intermediate stops at other floors. All pending destinations are deleted and passengers in the elevator car are requested by an audible signal to exit at the next landing. Activation by authorised persons.\*

\* Possibly with restrictions on elevator use for other passengers.

# GET TO KNOW OUR TERMINALS

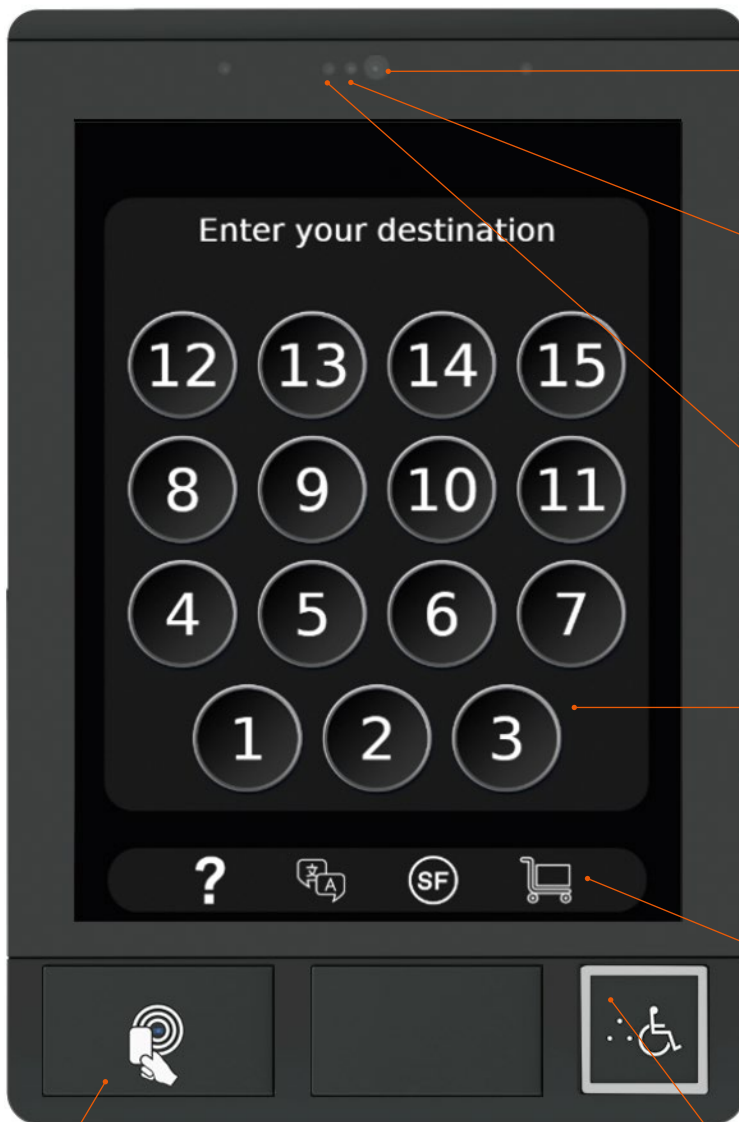

## Camera (optional)

Consult your TK Elevator representative for availability.

## Ambient light sensor

Adjusts the display brightness based on the prevailing light conditions.

## Motion sensor

Changes display brightness when motion is detected and dims when there is no motion near the terminal.

## Touchscreen

For entering the selected destination. Also displays the direction to the assigned elevator.

## Dock area

Used for getting to settings, opening the help screens and various other functions.

## Accessibility button (optional)

Hardware button to support disabled people with acoustic guidance and extending walking and door dwell times. Complies with EN 81-70.

## RFID card reader (optional)

Links to access control systems to gain access to restricted floors or to activate special functions.

# Terminal 12"



Black anodised aluminum frame with black-edged screen

## Terminal 12" dimensions

Large touchscreen	Dimension
Height	355 mm
Width	236 mm
Angled wall mount depth	102 mm
Flush wall mount depth	65 mm

## Terminal 12" display information

Display size	12" diagonal
Resolution	1024 (H) x 768 (V) pixel
Display colours	16 million
Ratio	4:3
Backlight life	50,000 hours
Mode	Normally white
Brightness	400 cd/m <sup>2</sup>

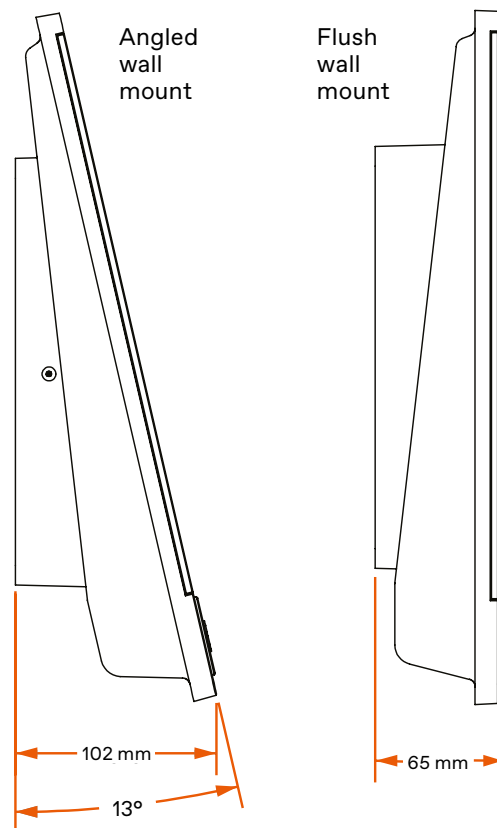

# Terminal 7"



Black anodised aluminum frame with black-edged screen

## Terminal 7" dimensions

Small touchscreen	Dimension
Height	247 mm
Width	118 mm
Angled wall mount depth	86 mm
Flush wall mount depth	59 mm

## Terminal 7" display information

Display size	7" diagonal
Resolution	1280 (H) x 800 (V) pixel
Display colours	16 million
Ratio	16:10
Backlight life	50,000 hours
Mode	Normally white
Brightness	400 cd/m <sup>2</sup>

Angled wall mount

Flush wall mount

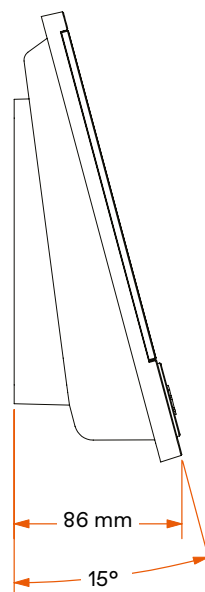

# Finish options

## Black anodised aluminum frame with black-edged screen



Terminal 12"



Terminal 7"

## Polished aluminum frame with white-edged screen



Terminal 12"



Terminal 7"



## Turnstile display

Another benefit of AGILE Destination Controls is its easy integration into a building's security system. A turnstile security system may already exist – or may be in the planning stages. If this is the case, the terminal display (without modules) is available to direct passengers to their floor, once they have swiped their security card at the card reader.

### Turnstile terminal dimensions

Touchscreen	Dimension
Height	245 mm
Width	107 mm
Angled wall mount depth	90 mm
Flush wall mount depth	62 mm

### Turnstile display information

Display size	7" diagonal
Resolution	1280 (H) x 800 (V) pixel
Display colours	16 million
Ratio	16:10
Backlight life	50,000 hours
Mode	Normally white
Brightness	400 cd/m <sup>2</sup>

## Design variants

Terminal 7"	Installation in customer-fitted turnstile	Installation with bracket on customer-fitted turnstile
Main characteristics	Flush-fitted installation	Structure inclined to the operator
Hardware in the frame	Without camera but with ambient light sensor and proximity sensor	
Module area (hardware)	Fitted with dummy elements, i. e. without card reader, accessibility button, etc.	

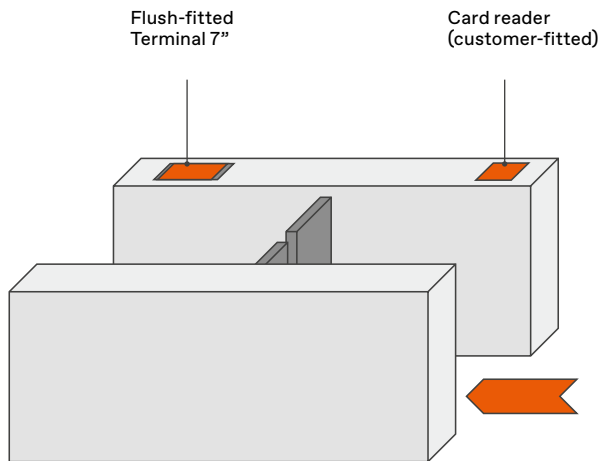

Installation in customer-fitted turnstile

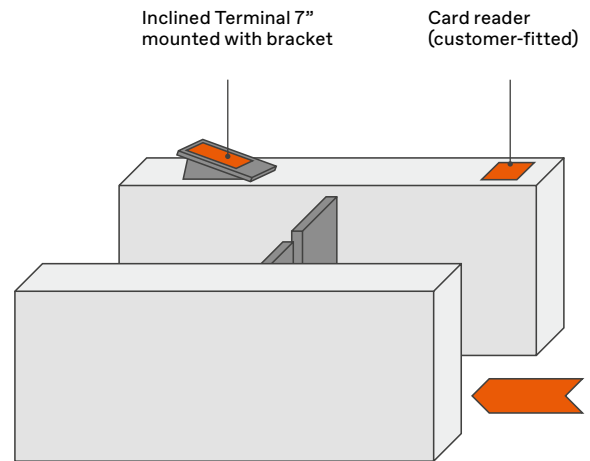

Installation with bracket on customer-fitted turnstile



# MODULES

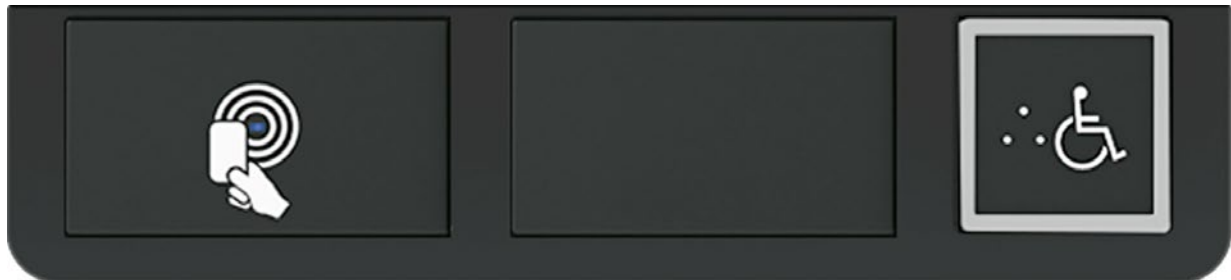

## RFID card reader\*

A card reader featuring contactless technology is an available option. This allows users to quickly present their cards and gain access to a secure floor or special features.

Optionally, a contactless RFID card reader (Radio Frequency Identification) can be configured for the terminal. This is securely installed below the touchscreen in the module strip. Passengers can identify themselves by swiping a corresponding RFID card and, in the process, trigger order-dependent functions: enabling access authorisations, automatic elevator requests or special elevator functions such as VIP runs. A prerequisite for these functions is an access control system geared to the elevator system.

\* During planning, it must be ensured that the transponders used in the building are compatible and that there is also a suitable interface to any existing or planned access control system (hardware and software).

## Camera\*

Optionally, a camera can be configured for the terminal. This is securely installed in the center of the upper part of the screen frame.

\* Consult your TK Elevator representative for availability.

## Dummy element

If no optional modules or only individual optional modules are selected, neutral dummy elements are inserted in the module stripe below the display of the terminal corresponding to the base colour of the terminal (black or white) without labelling.

## Tactile Accessibility button

Guarantees accessibility to lifts, especially for disabled people in accordance with acc. to EN 81-70. Ensures that all users can efficiently move to their destination.

Optionally, an accessibility button for people with restricted capabilities in accordance with EN 81-70 can be configured with a wheelchair symbol for the terminal. This is integrated below the touch-screen in the module strip. Passengers can use this to activate special functions. The button corresponds to the EN 81-70 specifications. When the accessibility button is operated, all accessible landings are listed per voice announcement in ascending order. Pressing the button a second time selects the last-named landing as the destination landing and the corresponding elevator is announced.

## Terminal specifications

Display colours	16 million
Brightness	400 cd/m <sup>2</sup>
Backlight LED	50,000 hours (lifetime on full brightness)
Power requirement	Standard: PoE (Power over Ethernet), Optional: separate 24 V supply
Operating system	Linux
CPU	Freescale i.MX6 dual-core
DRAM	1GB DDR3L
System storage	4GB NAND flash
Communication	Ethernet or PoE, CAN, RS-232
Ethernet network	10/100 Mbps
Card reader	HID iCLASS SE <sup>®</sup> reader module
Rating	IPX3
Temperature (operating)	0 to 50 degrees C (32 to 122 degrees F), indoor use only
Standby mode	Yes, after a period of inactivity (time period is adjustable in the Design Center application)

## Configuration options for hardware in the terminal

### Terminal 7"



Terminal 7" with accessibility button and one dummy element



Terminal 7" with accessibility button and RFID card reader

### Terminal 12"



Terminal 12" with accessibility button and two dummy elements



Terminal 12" with accessibility button, RFID card reader and one dummy element

Not every configuration option shown here.

# PEDESTALS

## Design options

### Covering cap (top)



Gray paint coating  
(NCS S 1502B)  
Metallic look



Black powder coating  
(RAL 9005)



Polished aluminum  
(Electropainting)



White powder coating  
(NCS S 0907-R90B)

Material: Aluminum alloy 6063A.

### Pedestal body

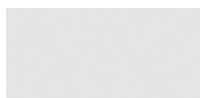

White powder coating  
(NCS S 0907-R90B)



Black powder coating  
(RAL 9005)



Gray paint coating  
(NCS S 1502B)  
Metallic look

Material: Aluminum alloy 6063A.

### Side covers (left/right)



Gray paint coating  
(NCS S 1502B)  
Metallic look



Black powder coating  
(RAL 9005)



Polished aluminum  
(Electro-painting)

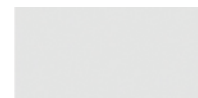

White powder coating  
(NCS S 0907-R90B)

Material: Aluminum alloy 6063A.

### Side covers with LED lighting (optional)



Red



Green



Blue



Orange



White

Side covers with opalescent ABS (shiny plastic) and LED strips behind. Power supply 24 V DC. Narrow pedestal for Terminal 7": strip with 196 LEDs. Wide pedestal for Terminal 12": strip with 210 LEDs.



# Pedestal versions

## Embedded pedestal



Terminal 7"

Terminal 12"

## Surface-mounted pedestal



Terminal 7"

Terminal 12"

Installation of the pedestals must ensure that the center of the accessibility button is at a height of 1076 mm above the finished floor.

# Dimensions with mounted terminal

## Terminal 7"

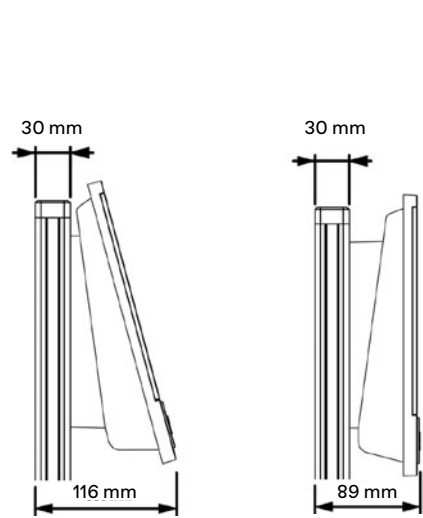

Installation inclined to mounting surface

Installation parallel to mounting surface

## Terminal 12"

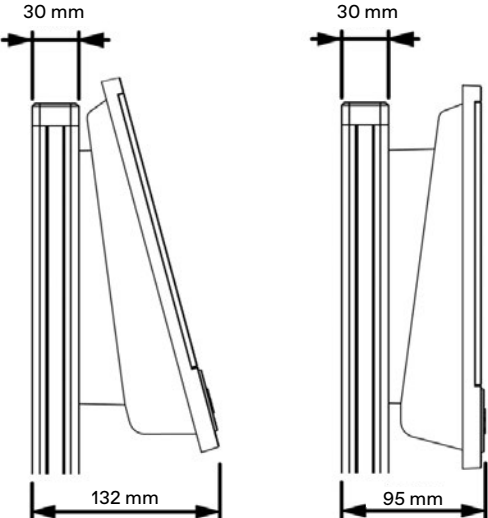

Installation inclined to mounting surface

Installation parallel to mounting surface

# WALL COVERS

## Design options



### Cover caps (top/bottom)



Gray paint coating  
(NCS S 1502B)  
Metallic look



Black powder coating  
(RAL 9005)



Polished aluminum  
(Electropainting)



White powder coating  
(NCS S 0907-R90B)

Material: Aluminum alloy 6063A.

### Cover body

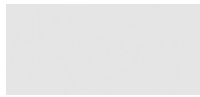

White powder coating  
(NCS S 0907-R90B)



Black powder coating  
(RAL 9005)



Gray paint coating  
(NCS S 1502B)  
Metallic look

Material: Aluminum alloy 6063A.

### Side covers (left/right)



Gray paint coating  
(NCS S 1502B)  
Metallic look



Black powder coating  
(RAL 9005)



Polished aluminum  
(Electro-painting)

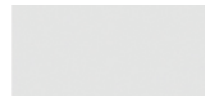

White powder coating  
(NCS S 0907-R90B)

Material: Aluminum alloy 6063A.

### Side covers with LED lighting (optional)



Red



Green



Blue



Orange



White

Side covers with opalescent ABS (shiny plastic) and LED strips behind.  
Power supply 24 V DC. Wall cover: strip with 105 LEDs.

## Wall cover versions

### Half height, narrow version

### Half height, wide version



Terminal 7"



Terminal 7"  
alternative installation (rotated)



Terminal 7"



Terminal 12"

Installation of the wall covers must ensure that the center of the accessibility button is at a height of 1076 mm above the finished floor.  
Additional version: Half height, narrow/wide versions without recesses for flexible installation height.

## Dimensions with mounted terminal

### Terminal 7"

### Terminal 12"

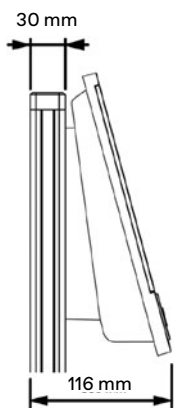

Installation inclined to mounting surface



Installation parallel to mounting surface

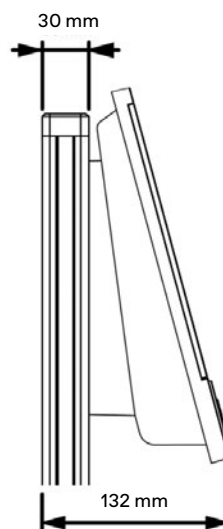

Installation inclined to mounting surface

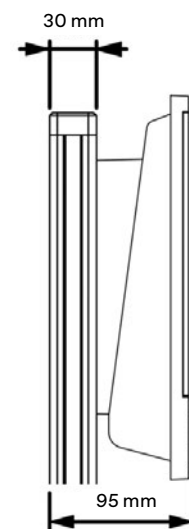

Installation parallel to mounting surface

# SLIM WALL COVERS



## Design options

### Cover caps (top/bottom)



Gray paint coating  
(NCS S 1502B)  
Metallic look



Black powder coating  
(RAL 9005)



Polished aluminum  
(Electropainting)



White powder coating  
(NCS S 0907-R90B)

Material: Aluminum alloy 6063A.

### Cover body

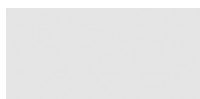

White powder coating  
(NCS S 0907-R90B)



Black powder coating  
(RAL 9005)



Gray paint coating  
(NCS S 1502B)  
Metallic look

Material: Aluminum alloy 6063A.

## Slim wall cover versions

### Full height, narrow/wide versions



Narrow version,  
Terminal 7"

Wide version,  
Terminal 12"

Wide version,  
Terminal 12"

### Half height, narrow/wide versions



Narrow version,  
Terminal 7"

Wide version,  
Terminal 12"

Installation of the wall covers must ensure that the center of the accessibility button is at a height of 1076 mm above the finished floor.  
Additional version: Half height, narrow/wide versions without recesses for flexible installation height.

## Dimensions with mounted terminal

### Terminal 7"

11.0 mm w/o cap  
13.5 mm with cap



97 mm

Installation inclined to  
mounting surface

11.0 mm w/o cap  
13.5 mm with cap



70 mm

Installation parallel to  
mounting surface

### Terminal 12"

11.0 mm w/o cap  
13.5 mm with cap

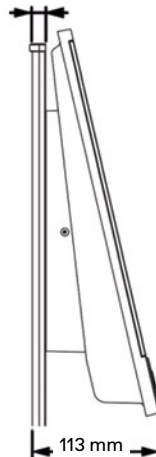

113 mm

Installation inclined to  
mounting surface

11.0 mm w/o cap  
13.5 mm with cap



76 mm

Installation parallel to  
mounting surface

# ADDING A PERSONAL TOUCH



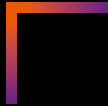

# AGILE DESIGN CENTER

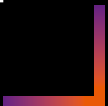

AGILE Design Center is an application that allows you to customise the touch-screens that direct elevator passengers to their destination.

Tailor your AGILE Destination Control Terminals to individualise the user experience by reflecting a tenant's brand identity or any other environmental or aesthetic aspects.

# THE DISPLAY LAYOUT STYLE

AGILE Destination Controls offers two standard themes for the display layout to seamlessly match with any building style. You can also choose from a variety of different request input possibilities and elevator assignment modes. Configure your display to meet your needs and taste.

## White theme

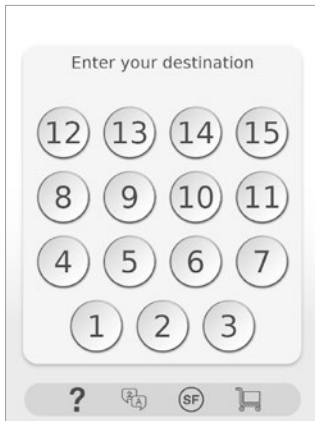

White theme and round buttons

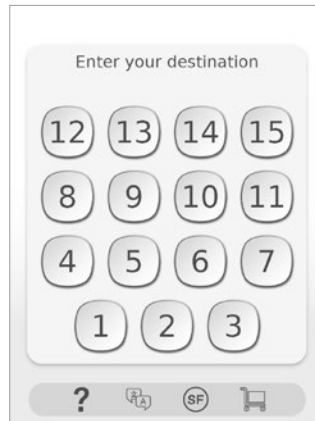

White theme and scround buttons



Round white button



Scround white button

## Black theme



Black theme and round buttons

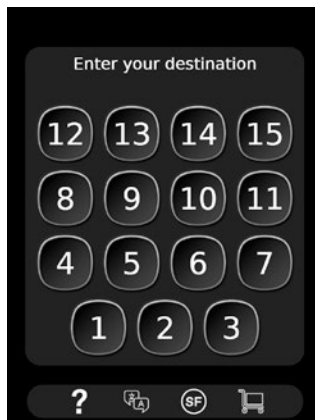

Black theme and scround buttons



Round black button



Scround black button

# Input modes

Depending on the number of landings, various arrangements of the touch buttons for input destination requests are possible.

## Round buttons

## Scround buttons

Terminal 7"

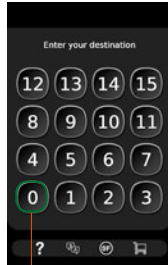
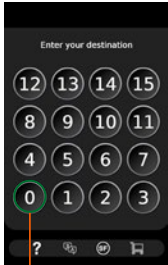

## One touch button for each floor

One touch button specifying the floor number is displayed for each floor of the building. The desired destination floor is selected simply by pressing the corresponding touch button. The elevator selected by the system is then displayed.

### Green touch buttons for main entrance level

For better orientation, the main entrance level (entrance/exit of the building) can be shown with a green touch button. This makes operation considerably easier.

Terminal 12"

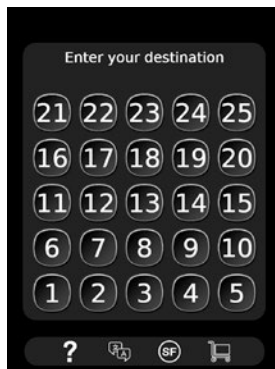
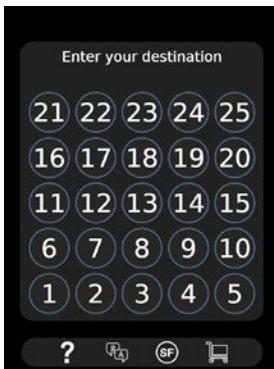

Terminal 7"

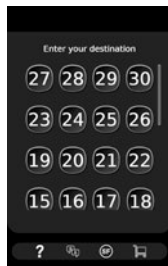
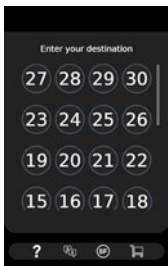

## Input via scrolling screen

With a large number of floors, only part of the touch buttons is visible in the display. The selection of all touch buttons for each floor can be shifted upwards or downwards with a finger. As soon as the desired destination landing is visible, the corresponding destination floor can be selected.

Terminal 12"

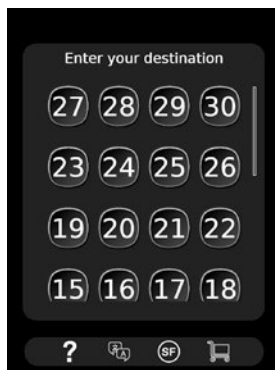
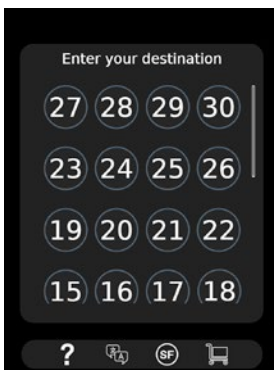

# Input modes

## Round buttons

## Scround buttons

Terminal 7"

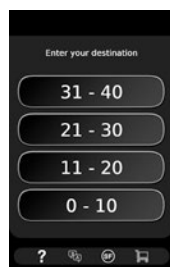
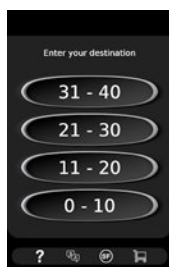

## Multi-stage input via range selection (range button)

With a large number of floors, the touch buttons become too small to show all floors at a glance. Multi-stage input helps passengers to get to their destination faster. The ranges can refer to floor numbers (e.g. 1 – 10, 11 – 20) or to different occupants of the building (e.g. company X, company Y).

Terminal 12"



Terminal 7"

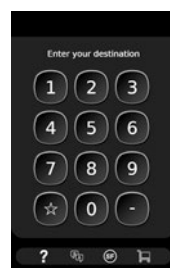
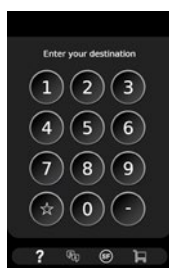

## Virtual numeric keypad (EN 81-70 compliant, depending on version)

The destination floor is selected via direct input of the floor number using the touch button of a virtual numeric keypad. This input method is particularly suitable for buildings with a large number of floors.

Terminal 12"

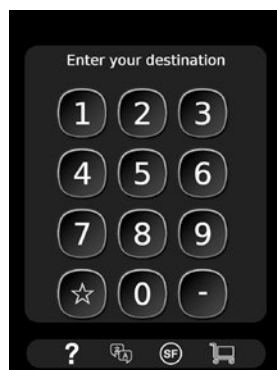
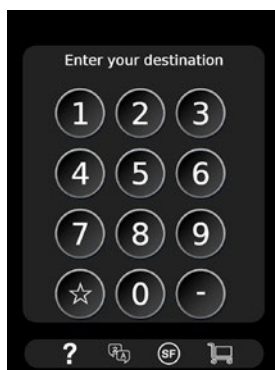

# Input modes

## Round buttons

## Scround buttons

Terminal 7"



## Input via accessibility button (for disabled people in accordance with EN 81-70)

When the accessibility button is operated, the floor numbers are listed audibly in ascending order via the built-in loudspeaker. As soon as the desired destination floor has been announced, the accessibility button must be pressed again. This confirms that floor as the destination floor. The elevator selected by the system is then announced.

Terminal 12"



Screen layouts are identical for all styles.

## Input via RFID card reader with access control system

This form of input depends on the installed access control system. Locked floors can be unlocked via access card and the desired floor can then be selected.

Terminal 7"



Terminal 12"



# Elevator assignment modes

Following input of the desired destination floor, the elevator selected by the system is displayed on the touchscreen. You can choose from two modes: label design and map design.

## Standard

Terminal 7"



Terminal 12"



### Label design (design with alphanumeric marking)

The designation of the elevator is in the form of letter and/or number.

## Alternative 1

Terminal 7"

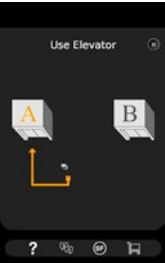

## Alternative 2

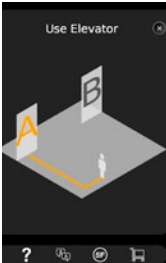

### Automatic map design

The display shows a plan (top view) indicating how the elevators are arranged. The assigned elevator is highlighted in colour and the route from the terminal to the elevator is shown.

Terminal 12"





## Managing your own individualisation

With AGILE Design Center, you have the flexibility to easily configure the layout of your screen design on your own, on site.

Clear, concise graphics make the terminal easy for passengers to use. In addition, user-friendly software enables you to personalise screen designs. You can define all configurations on a PC or remotely via hand-held devices.

### Benefits

- Easily customisable touch-screens enable you to create a distinctive, individualised design
- Existing templates available for button layouts
- Pre-loaded backgrounds and colours – or upload your own, to underline special events or seasons
- Energy-saving adjustments such as display brightness and sleep mode time-out setting
- Surprise individual passengers or groups with individualised welcome messages

## Personal message

AGILE Design Center enables you to post topical messages for passengers or to represent your company with your logo.

## Choose your theme

Choose from our library of existing layout themes and pre-defined button styles.

## General settings

Speaker volume, screen brightness, card swipe confirmation sound, timer for terminal sleep mode and much more.

Depending on your chosen layout and requested input mode, some customisation options may not be available.



# AGILE DESIGN CENTER

## An impressive background

Upload your own background images or choose from pre-loaded designs and colours.



Create a powerful first impression with an individualised theme for your terminal. Current or prospective tenants and visitors will appreciate the attractive, easy-to-use terminal experience. And via AGILE Design Center you can easily do all this yourself.

## Arrange your buttons

Menu buttons can be moved around or removed.

Choose from pre-loaded themes and backgrounds or personalise your look by uploading images and messages. With AGILE Design Center, building management staff can create individualised touchscreens that are easy for passengers to use – on one terminal at a time, selected terminals or all terminals at once. With a wide variety of design options to choose from, you can create a unique look that reflects your building and modify various features in the AGILE Design Center application.



[WWW.TKELEVATOR.COM](http://WWW.TKELEVATOR.COM)